

4

3

2

1

| REVISIONS |     |                       |          |       |
|-----------|-----|-----------------------|----------|-------|
| ZONE      | REV | DESCRIPTION           | DATE     | DRAWN |
|           | A   | RELEASE FOR PRODUCTS. | 96.10.11 | Allan |
|           |     |                       |          |       |

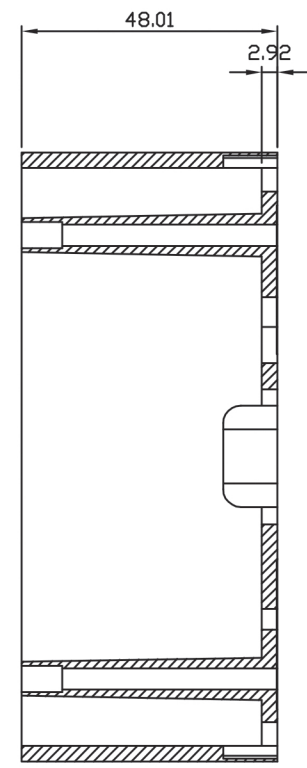
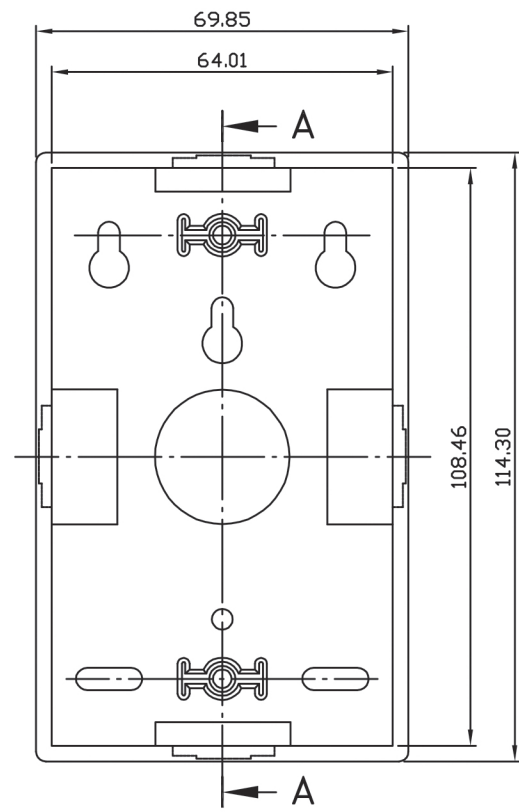

SECTION: A-A

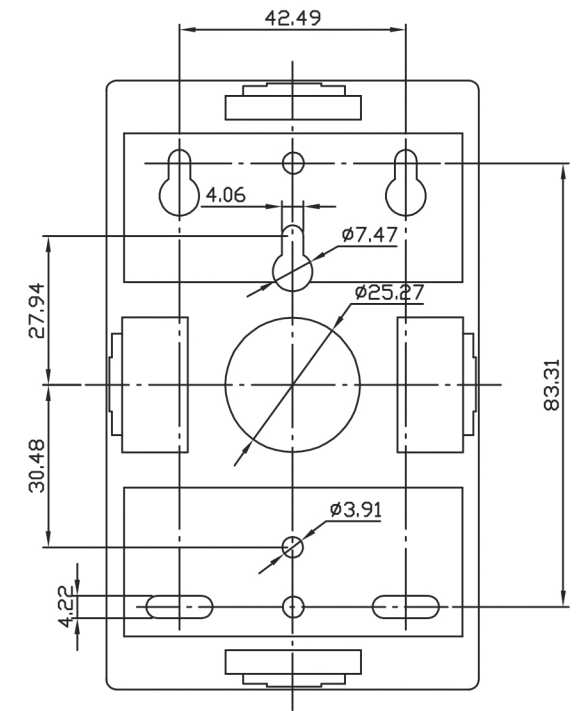

## NOTES:

- 1.MATERIAL:ABS,MUST MEET UL94V-0 RATING.
- 2.INSTALL #6-32 THREADED BRASS INSERT.

| UNLESS OTHERWISE SPECIFIED:<br>TOLERANCES |           |          | PROJECT ID |          | <b>weltron</b> <sup>®</sup>                     |                         |              |  |
|---|-----------|----------|------------|----------|---|-------------------------|--------------|--|
| INCH                                      | MM        | ANGULAR  | 1064A      |          | TITLE<br>SINGLE GANG 1.89 DEPTH<br>MOUNTING BOX |                         |              |  |
| .X ± .016                                 | .X ± 0.2  | X ± 1°   | FILE       | DATE     |   |                         |              |  |
| .XX ± .008                                | .XX ± 0.1 | .X ± .5° | Z1090.DWG  | 96.10.11 | DRAWN<br><i>Allan</i>                           |                         |              |  |
| .XXX ± .004                               |           |          | MATERIAL   | CHECK    | PART NUMBER<br>44-795 XX                        |                         |              |  |
|   |           |          | SURFACE    | APPROVED | SIZE<br>A4                                      | DRAWING NUMBER<br>Z1090 | REV<br>A     |  |
|   |           |          |            |          | SCALE<br>1:1                                    | UNIT<br>mm              | SHEET 1 OF 1 |  |