

NOTES:FINISH (PLATING THICKNESS IN MICRO-INCHES)

- 1.BRASS PER QQ-B-626
- 2.PHOSPHOR BRONZE PER QQ-B-750
- 3.NICKEL PL.100 MIN. THICK OVER COPPER STRIKE
- 4.GOLD PL.3 MIN THICK OVER NICKEL PL.100 MIN. THICK OVER COPPER STRIKE

REVISIONS

RevNo	Description	Date	Revision	Mender
1				
2				

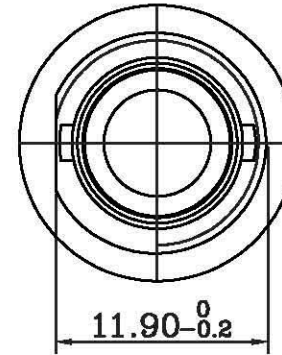
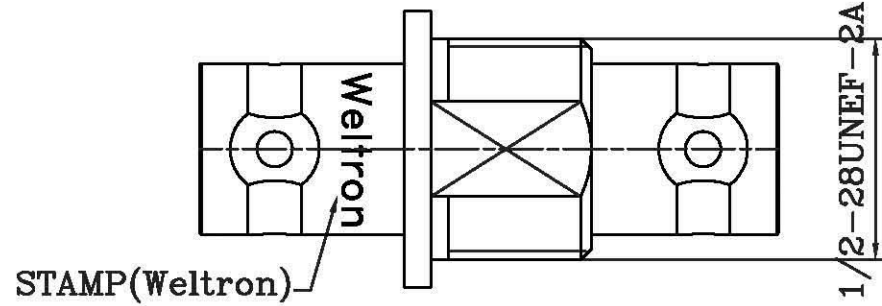

ROHS Compliant

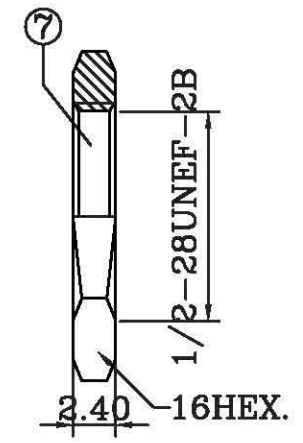
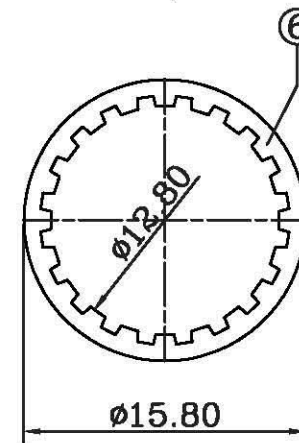
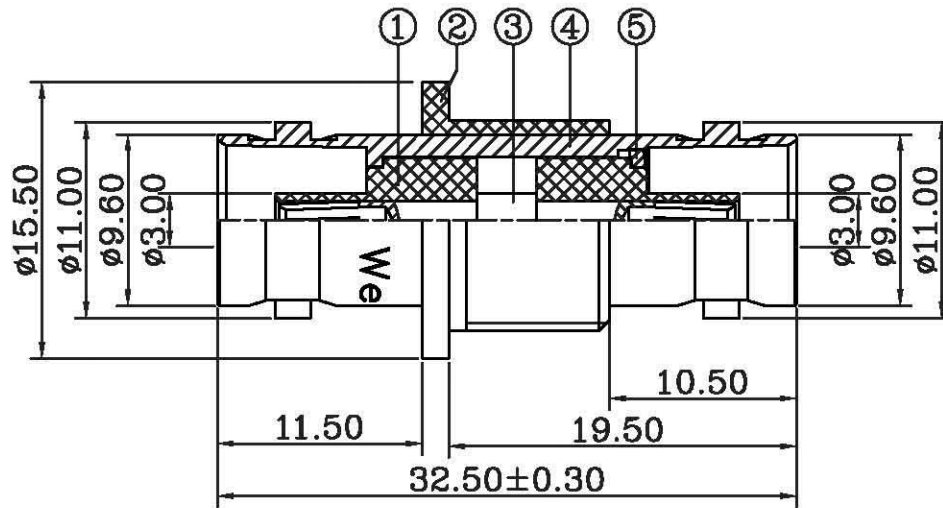

7	NUT	NOTE 1	1	NOTE 3
6	LOCK WASHER	IRON	1	NOTE 3
5	WASHER	IRON	1	NOTE 3
4	BODY	NOTE 1	1	NOTE 3
3	CONTACT PIN	NOTE 2	1	NOTE 4
2	INSULATOR BODY	PBT	1	WHITE
1	INSULATOR	POM	2	NATURAL
ITEM	DESCRIPTION	MATERIAL	Q'TY	FINISHED

weltron®				TITLE BNC DOUBLE FEMALE BULKHEAD ADAPTOR, 75 OHM (WITH ISOLATION RINGS)		
PART NO.	44-253IS-75	UNITS	MM	UNLESS OTHERWISE SPECIFIED TOLERANCES: 0.5-15 = ±0.15 15-30 = ±0.30 30-120 = ±0.60 >120 = ±1.00	DESIGNED	NQ
		SCALE	FIT		DRAWING	NQ
MODEL NO.		EDITION	A1	PUBLISH DATE	APPROVED	Andy
CAD FILE	Yin sheng/Yifaxing/SB/SB132			2011/09/22	3RD ANGLE	