

ROHS Compliant

REVISIONS				
RevNo	Description	Date	Revision	Mender
1				
2				

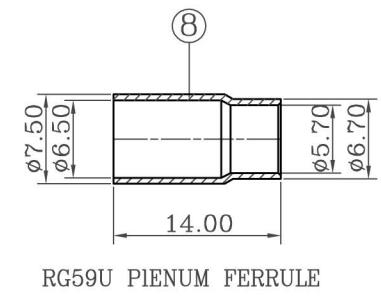
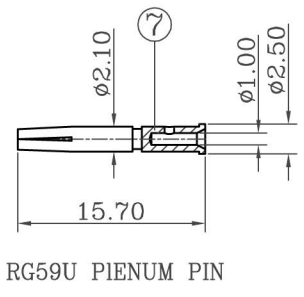
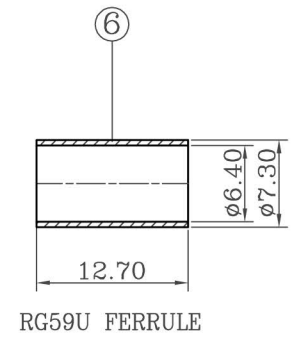
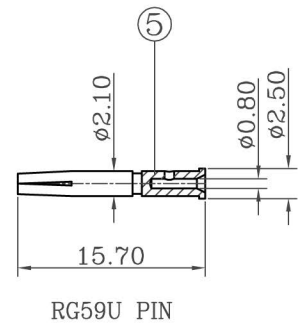
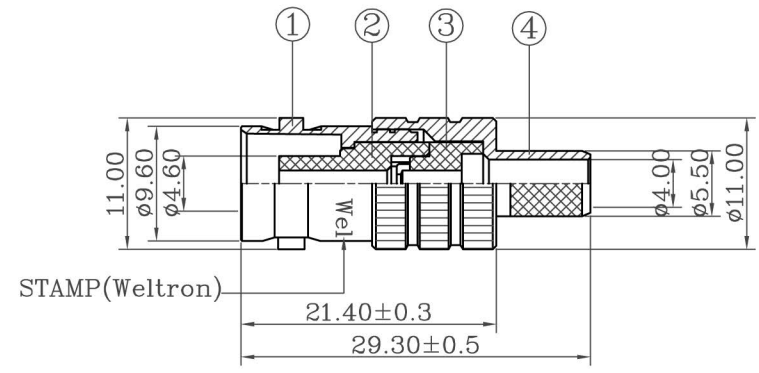

- NOTES:FINISH (PLATING THICKNESS IN MICRO-INCHES)
- 1.BRASS PER QQ-B-626
  - 2.NICKEL PL.100 MIN. THICK OVER COPPER STRIKE
  - 3.GOLD PL.3 MIN THICK OVER NICKEL PL.100 MIN. THICK OVER COPPER STRIKE
  - 4.JIS H 3250,C 2700

- 1.CRIMPED FERRULE HEX CRIMP SIZE .255"
- 2.CRIMPED CONTACT PIN HEX CRIMP SIZE .068" OR TO SOLDER

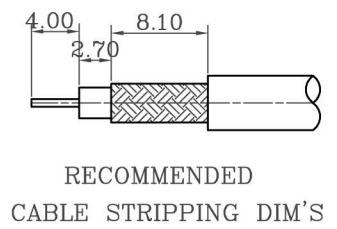

8	FERRULE	NOTE 4	1	NOTE 2
7	CONTACT PIN	NOTE 1	1	NOTE 3
6	FERRULE	NOTE 4	1	NOTE 2
5	CONTACT PIN	NOTE 1	1	NOTE 3
4	REAR BODY	NOTE 1	1	NOTE 2
3	INSULATOR	POM	1	WHITE
2	INSULATOR	POM	1	WHITE
1	BODY	NOTE 1	1	NOTE 2
ITEM	DESCRIPTION	MATERIAL	Q'TY	FINISHED

**Weltron®**

DRAWING NO.		UNITS	MM
MODEL NO.		SCALE	FIT
PART NO.	<b>44-283</b>	EDITION	
CAD FILE			

TITLE BNC FEMALE CRIMP TYPE 50 OHMS FOR RG59U, RG59U PIENUM CABLE

UNLESS OTHERWISE SPECIFIED TOLERANCES:	DESIGNED
0.5-15 = ±0.15	DRAWING
15-30 = ±0.30	CHECKED
30-120 = ±0.60	APPROVED
>120 = ±1.00	
ANGLES ±5°	
PUBLISH DATE	2011/03/19
	3RD ANGLE