

ROHS Compliant

REVISIONS

RevNo	Description	Date	Revision	Mender
1				
2				

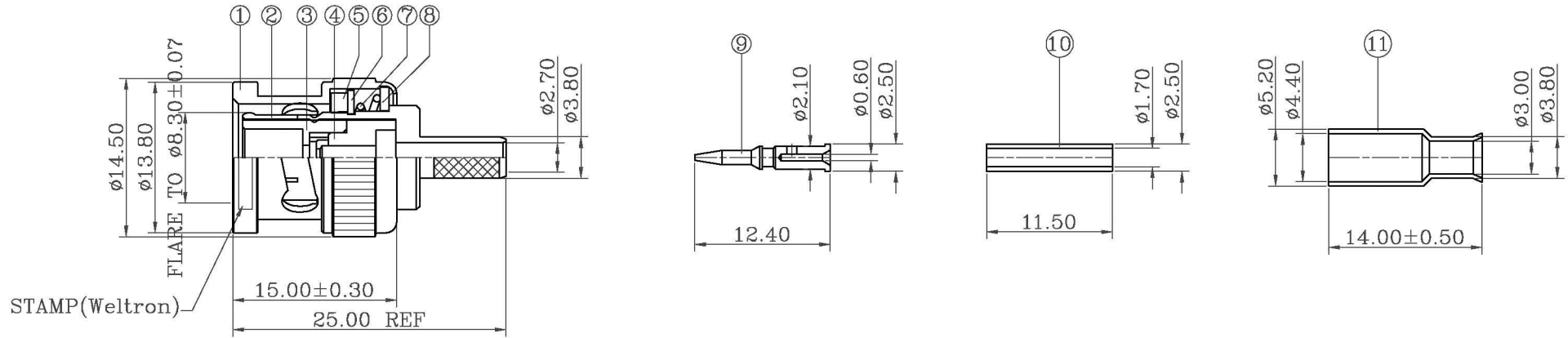

NOTES:FINISH (PLATING THICKNESS IN MICRO-INCHES)

- 1.BRASS PER QQ-B-626
- 2.NICKEL PL.100 MIN. THICK OVER COPPER STRIKE
- 3.GOLD PL.3 MIN THICK OVER NICKEL PL.100 MIN. THICK OVER COPPER STRIKE
- 4.JIS H 3250,C 2700

- 1.CRIMPED FERRULE
HEX CRIMP SIZE .178"
- 2.CRIMPED CONTACT PIN
HEX CRIMP SIZE .068"

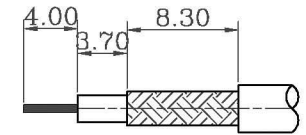

RECOMMENDED
CABLE STRIPPING DIM'S

11	FERRULE	NOTE 4	1	NOTE 2
10	SLEEVE	POM	1	NATURAL
9	CONTACT PIN	NOTE 1	1	NOTE 3
8	WASHER	IRON	1	NOTE 2
7	SPRING	65Mn	1	NATURAL
6	RETAINER RING	65Mn	1	NOTE 2
5	GASKET	RUBBER	1	RED
4	INSULATOR	POM	1	NATURAL
3	INSULATOR	POM	1	NATURAL
2	BODY	NOTE 1	1	NOTE 2
1	SHELL	NOTE 1	1	NOTE 2
ITEM	DESCRIPTION	MATERIAL	Q'TY	FINISHED

weltron [®]				TITLE		
				BNC CRIMP PLUG 50 OHMS (FOR RG174U CABLE)		
PART NO.	44-290-174	UNITS	MM	UNLESS OTHERWISE SPECIFIED TOLERANCES: 0.5-15 = ±0.15 15-30 = ±0.30 30-120 = ±0.60 >120 = ±1.00	DESIGNED	<i>Xwj</i>
		SCALE	FIT		DRAWING	<i>Ckg</i>
MODEL NO.		EDITION	A1	PUBLISH DATE	APPROVED	<i>Andy</i>
DRAWING NO.				2009/11/24	3RD ANGLE	
CAD FILE						