

REVISIONS				
RevNo	Description	Date	Revision	Mender
1				
2				

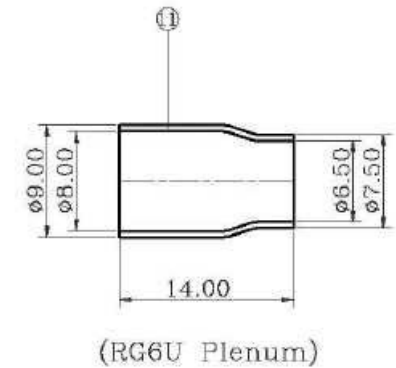
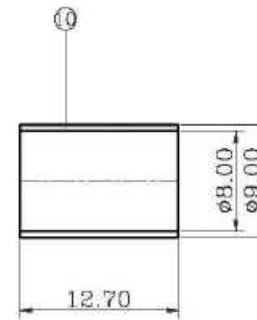
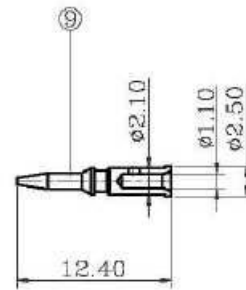
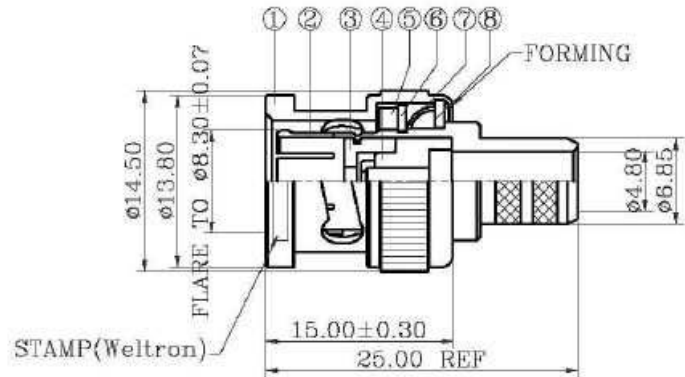

NOTES:FINISH (PLATING THICKNESS IN MICRO-INCHES)

- 1.BRASS PER QQ-B-626
- 2.NICKEL PL.100 MIN. THICK OVER COPPER STRIKE
- 3.GOLD PL.3 MIN THICK OVER NICKEL PL.100 MIN. THICK OVER COPPER STRIKE
- 4.JIS H 3250,C 2700

ROHS Compliant

- 1.CRIMPED FERRULE
HEX CRIMP SIZE .306"
- 2.CRIMPED CONTACT PIN
HEX CRIMP SIZE .068"
OR TO SOLDER

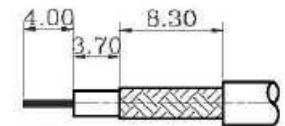

RECOMMENDED
CABLE STRIPPING DIM'S

44-290-6-75

11	FERRULE	NOTE 4	1	NOTE 2
10	FERRULE	NOTE 4	1	NOTE 2
9	CONTACT PIN	NOTE 1	1	NOTE 3
8	WASHER	NOTE 1	1	NOTE 2
7	SPRING	SK5	1	NOTE4
6	RETAINER RING	NOTE 1	1	NOTE 2
5	GASKET	RUBBER	1	RED
4	INSULATOR	POM	1	NATURAL
3	INSULATOR	POM	1	NATURAL
2	BODY	NOTE1	1	NOTE 2
1	SHELL	NOTE1	1	NOTE 2
ITEM	DESCRIPTION	MATERIAL	Q'TY	FINISHED

weltron [®]				TITLE	
PART NO.		44-290-6-75	UNITS	MM	BNC PLUG CRIMP FOR RG6U,BEL 1684A CABLE, 75 OHMS
MODEL NO.			SCALE	FIT	UNLESS OTHERWISE SPECIFIED TOLERANCES:
DRAWING NO.			EDITION	A1	0.5-15 = ±0.15 ANGLES ±5°
CAD FILE		Yin sheng/Yifaxing/SB/SB105	PUBLISH DATE		2010/10/27
			DESIGNED		NQ
			DRAWING		NQ
			CHECKED		David
			APPROVED		Andy
					3RD ANGLE