

ROHS Compliant

REVISIONS				
RevNo	Description	Date	Revision	Mender
1				
2				

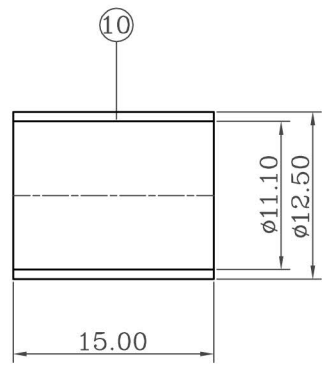

NOTES:FINISH (PLATING THICKNESS IN MICRO-INCHES)
 1.BRASS PER QQ-B-626
 2.NICKEL PL.100 MIN. THICK OVER COPPER STRIKE
 3.GOLD PL.3 MIN THICK OVER NICKEL PL.100 MIN. THICK OVER COPPER STRIKE
 4.JIS H 3250,C 2700

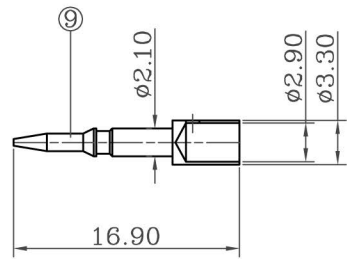
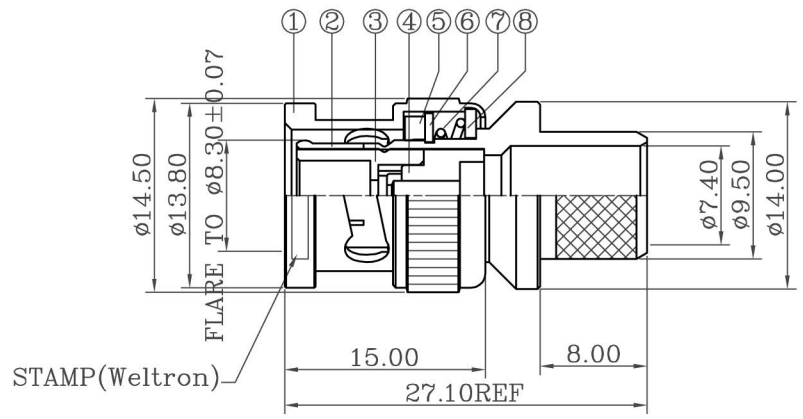
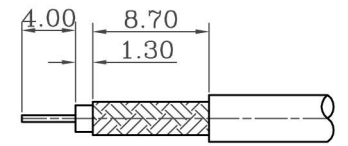

1.CRIMPED FERRULE
 HEX CRIMP SIZE .429"
 2.CRIMPED CONTACT PIN
 HEX CRIMP SIZE .100"
 OR TO SOLDER

RECOMMENDED
 CABLE STRIPPING DIM'S

ITEM	DESCRIPTION	MATERIAL	Q'TY	FINISHED
10	FERRULE	NOTE 4	1	NOTE 2
9	CONTACT PIN	NOTE 1	1	NOTE 3
8	WASHER	IRON	1	NOTE 2
7	SPRING	65Mn	1	NATURAL
6	RETAINER RING	65Mn	1	NOTE 2
5	GASKET	RUBBER	1	RED
4	INSULATOR	POM	1	NATURAL
3	INSULATOR	POM	1	NATURAL
2	BODY	NOTE 1	1	NOTE 2
1	SHELL	NOTE 1	1	NOTE 2

weltron[®]		TITLE BNC CRIMP PLUG 50 OHMS FOR LMR400,BELDEN9913,RG8U CABLE	
PART NO.	44-290-LMR400		TOLERANCES: 0.5-15 = ±0.15 ANGLES 15-30 = ±0.30 ±5°
MODEL NO.			
DRAWING NO.			
CAD FILE			3RD ANGLE