

ROHS Compliant

REVISIONS				
RevNo	Description	Date	Revision	Mender
1				
2				

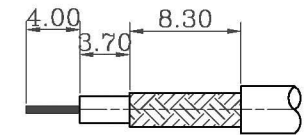
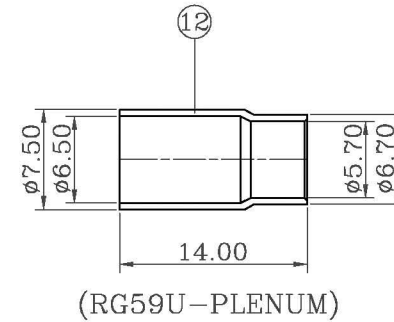
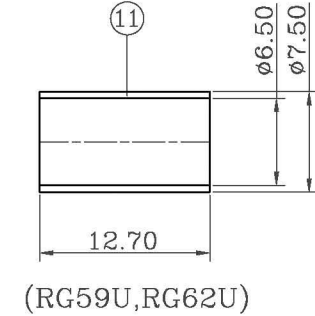
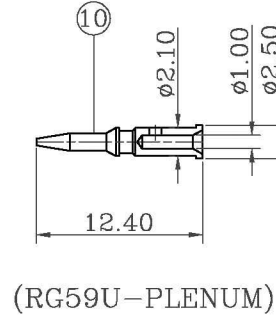
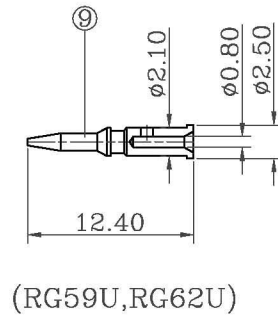
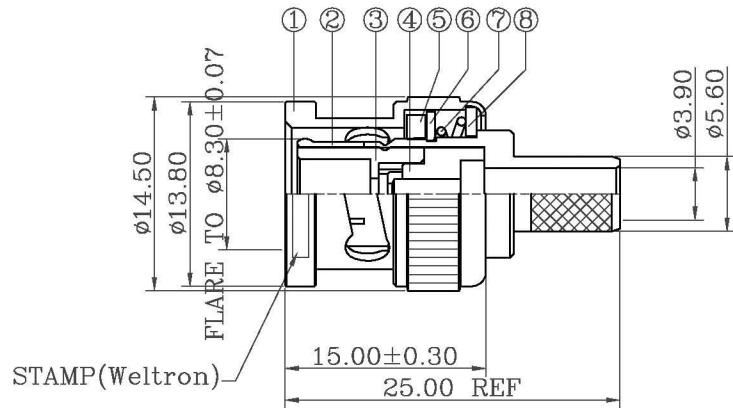

NOTES: FINISH (PLATING THICKNESS IN MICRO-INCHES)

- BRASS PER QQ-B-626
- NICKEL PL.100 MIN. THICK OVER COPPER STRIKE
- GOLD PL.3 MIN THICK OVER NICKEL PL.100 MIN. THICK OVER COPPER STRIKE
- JIS H 3250, C 2700

- CRIMPED FERRULE  
HEX CRIMP SIZE .255"
- CRIMPED CONTACT PIN  
HEX CRIMP SIZE .068"

RECOMMENDED  
CABLE STRIPPING DIM'S

44-290

12	FERRULE	NOTE 4	1	NOTE 2
11	FERRULE	NOTE 4	1	NOTE 2
10	CONTACT PIN	NOTE 1	1	NOTE 3
9	CONTACT PIN	NOTE 1	1	NOTE 3
8	WASHER	IRON	1	NOTE 2
7	SPRING	65Mn	1	NATURAL
6	RETAINER RING	65Mn	1	NOTE 2
5	GASKET	RUBBER	1	RED
4	INSULATOR	POM	1	NATURAL
3	INSULATOR	POM	1	NATURAL
2	BODY	NOTE 1	1	NOTE 2
1	SHELL	NOTE 1	1	NOTE 2
ITEM	DESCRIPTION	MATERIAL	Q'TY	FINISHED

<b>weltron</b> <sup>®</sup>				TITLE BNC CRIMP PLUG 50 OHMS (FOR RG59U, RG62U, RG59U-PLENUM CABLE)			
				UNLESS OTHERWISE SPECIFIED TOLERANCES: 0.5-15 = ±0.15 15-30 = ±0.30 30-120 = ±0.60 >120 = ±1.00	ANGLES ±5°	DESIGNED <i>Xwj</i>	DRAWING <i>Ckg</i>
DRAWING NO.		UNITS SCALE	MM FIT	PART NO. <b>44-290</b>	EDITION A1	PUBLISH DATE 2009/11/24	APPROVED <i>Andy</i>
MODEL NO.				CAD FILE			3RD ANGLE