

ROHS Compliant

REVISIONS

RevNo	Description	Date	Revision	Mender
1				
2				

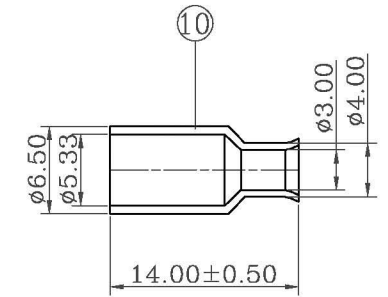
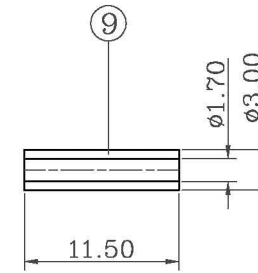
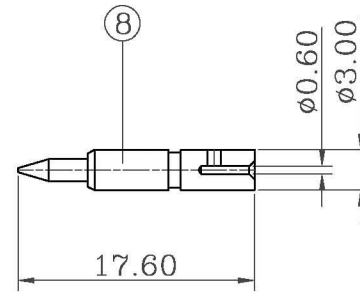
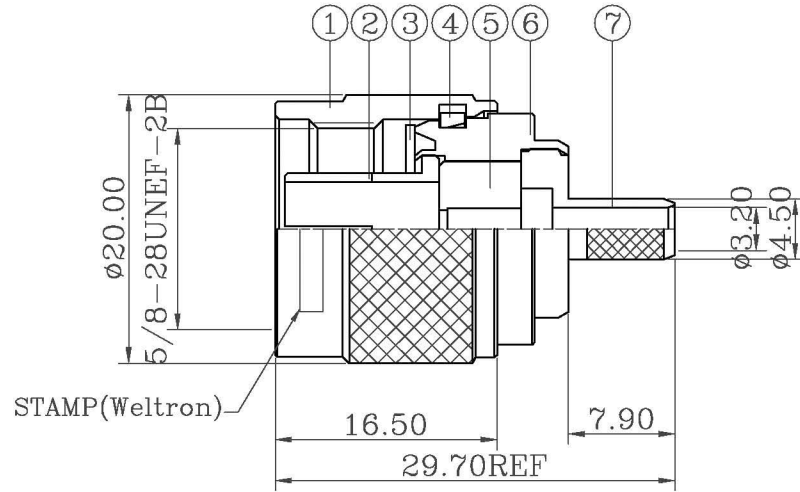

NOTES:FINISH (PLATING THICKNESS IN MICRO-INCHES)

- 1.BRASS PER QQ-B-626
- 2.SILVER PL.100 MIN. THICK OVER COPPER STRIKE
- 3.GOLD PL.3 MIN .THICK OVER NICKEL PL.100 MIN. THICK OVER COPPER STRIKE
- 4.TEFLON MIL-P-19468
- 5.JIS H 3250,C 2700

- 1.CRIMPED FERRULE
HEX CRIMP SIZE .213"
- 2.CRIMPED CONTACT PIN
HEX CRIMP SIZE .100"
OR TO SOLDER

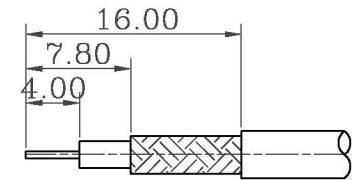

RECOMMENDED
CABLE STRIPPING DIM'S

44-262-174

10	FERRULE	NOTE 5	1	NOTE 2
9	SLEEVE	POM	1	NATURAL
8	CONTACT PIN	NOTE 1	1	NOTE 3
7	REAR BODY	NOTE 1	1	NOTE 2
6	BODY	NOTE 1	1	NOTE 2
5	INSULATOR	NOTE 4	1	NATURAL
4	RETAINER RING	NOTE 1	1	NATURAL
3	GASKET	RUBBER	1	RED
2	OUT CONTACT	NOTE 1	1	NOTE 2
1	SHELL	NOTE 1	1	NOTE 2
ITEM	DESCRIPTION	MATERIAL	Q'TY	FINISHED

Weltron [®]				TITLE		
PART NO.		44-262-174	UNITS	MM	N PLUG CRIMP 50 OHM FOR RG174,188,316/U CABLE	
MODEL NO.			SCALE	FIT	UNLESS OTHERWISE SPECIFIED TOLERANCES:	DESIGNED
					0.5-15 = ±0.15	<i>NQ</i>
					15-30 = ±0.30	DRAWING
					30-120 = ±0.60	<i>NQ</i>
					>120 = ±1.00	CHECKED
					ANGLES ±5°	<i>David</i>
CAD FILE			EDITION	A1	PUBLISH DATE	APPROVED
					2010/01/03	<i>Andy</i>
						3RD ANGLE