

ROHS Compliant

REVISIONS

RevNo	Description	Date	Revision	Mender
1				
2				

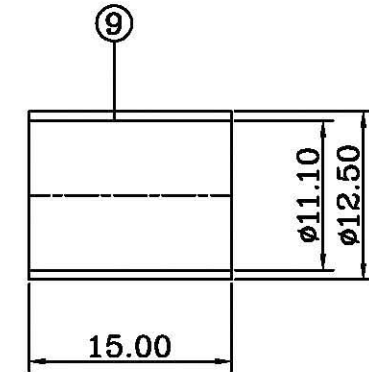
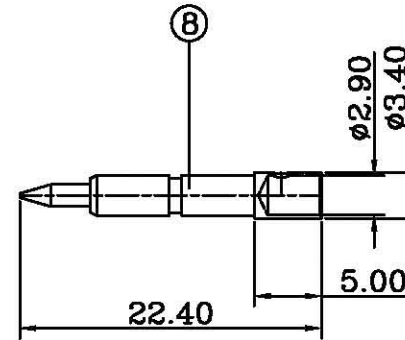
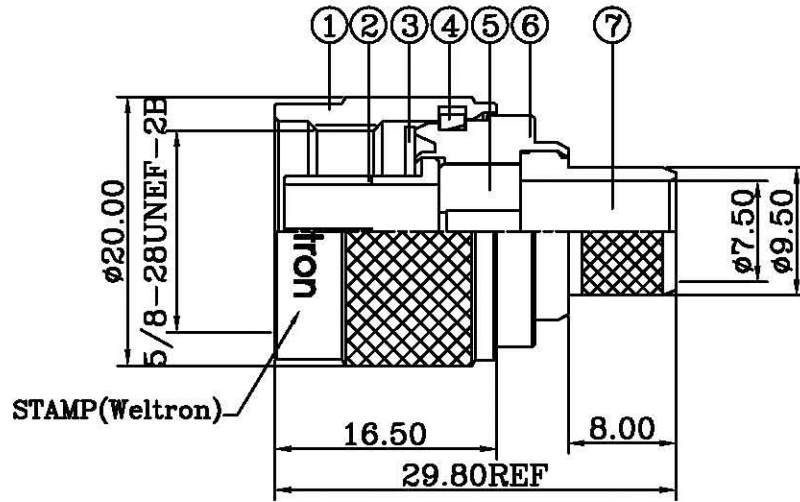

NOTES: FINISH (PLATING THICKNESS IN MICRO-INCHES)

- BRASS PER QQ-B-626
- SILVER PL.100 MIN. THICK OVER COPPER STRIKE
- GOLD PL.3 MIN THICK OVER NICKEL PL.100 MIN. THICK OVER COPPER STRIKE
- TEFLON MIL-P-19468
- JIS H 3250,C 2700

- CRIMPED FERRULE
HEX CRIMP SIZE .429"
- CRIMPED CONTACT PIN
HEX CRIMP SIZE .100"
OR TO SOLDER

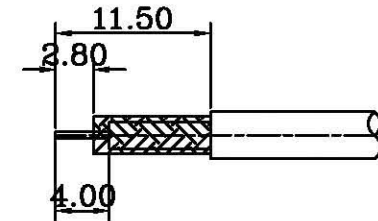

RECOMMENDED
CABLE STRIPPING DIM'S

9	FERRULE	NOTE 5	1	NOTE 2
8	CONTACT PIN	NOTE 1	1	NOTE 3
7	REAR BODY	NOTE 1	1	NOTE 2
6	BODY	NOTE 1	1	NOTE 2
5	INSULATOR	NOTE 4	1	NATURAL
4	RETAINER RING	NOTE 1	1	NATURAL
3	GASKET	RUBBER	1	RED
2	OUT CONTACT	NOTE 1	1	NOTE 2
1	SHELL	NOTE 1	1	NOTE 2
ITEM	DESCRIPTION	MATERIAL	Q'TY	FINISHED

weltron®				TITLE N PLUG CRIMP 50 OHM FOR RG8U, RG11U, RG213U		
PART NO.	44-262-8	UNITS	MM	UNLESS OTHERWISE SPECIFIED TOLERANCES: 0.5-15 = ±0.15 15-30 = ±0.30 30-120 = ±0.60 >120 = ±1.00	DESIGNED	NQ
		SCALE	FIT		ANGLES ±5°	DRAWING
MODEL NO.					CHECKED	David
		EDITION	A1	PUBLISH DATE	APPROVED	Andy
CAD FILE	Yin sheng/Yifaxing/SN/SN306			2010/01/03	3RD ANGLE	