

ROHS Compliant

REVISIONS

RevNo	Description	Date	Revision	Mender
1				
2				

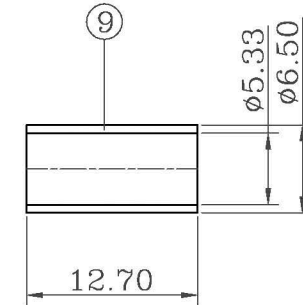
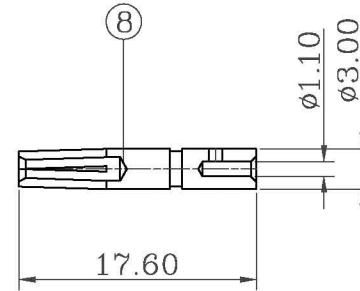
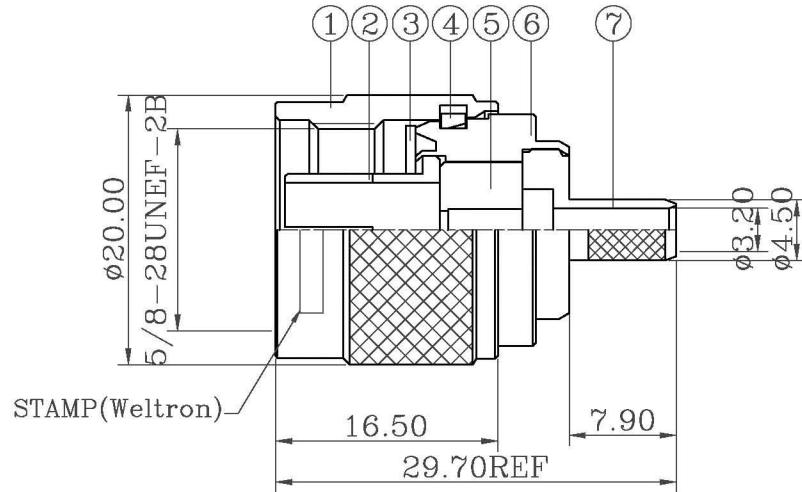

NOTES:FINISH (PLATING THICKNESS IN MICRO-INCHES)

- 1.BRASS PER QQ-B-626
- 2.SILVER PL.100 MIN. THICK OVER COPPER STRIKE
- 3.GOLD PL.3 MIN .THICK OVER NICKEL PL.100 MIN. THICK OVER COPPER STRIKE
- 4.TEFLON MIL-P-19468
- 5.JIS H 3250,C 2700

- 1.CRIMPED FERRULE
HEX CRIMP SIZE .213"
- 2.CRIMPED CONTACT PIN
HEX CRIMP SIZE .100"
OR TO SOLDER

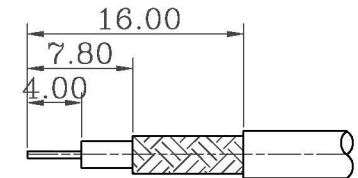

RECOMMENDED
CABLE STRIPPING DIM'S

9	FERRULE	NOTE 5	1	NOTE 2
8	CONTACT PIN	NOTE 1	1	NOTE 3
7	REAR BODY	NOTE 1	1	NOTE 2
6	BODY	NOTE 1	1	NOTE 2
5	INSULATOR	NOTE 4	1	NATURAL
4	RETAINER RING	NOTE 1	1	NATURAL
3	GASKET	RUBBER	1	RED
2	OUT CONTACT	NOTE 1	1	NOTE 2
1	SHELL	NOTE 1	1	NOTE 2
ITEM	DESCRIPTION	MATERIAL	Q'TY	FINISHED

weltron [®]				TITLE		
				RP N PLUG CRIMP 50 OHM FOR RG58,141U,LMR195 BELDEN8219 CABLE		
PART NO.	44-262RP-58	UNITS	MM	UNLESS OTHERWISE SPECIFIED TOLERANCES:	DESIGNED	NQ
		SCALE	FIT		0.5-15 = ±0.15 15-30 = ±0.30 30-120 = ±0.60 >120 = ±1.00	DRAWING
MODEL NO.				ANGLES ±5°	CHECKED	David
		EDITION	A1	PUBLISH DATE	APPROVED	Andy
CAD FILE				2009/11/24	3RD ANGLE	