

ROHS Compliant

REVISIONS				
RevNo	Description	Date	Revision	Mender
1				
2				

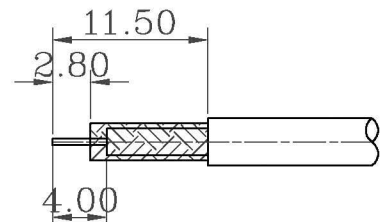
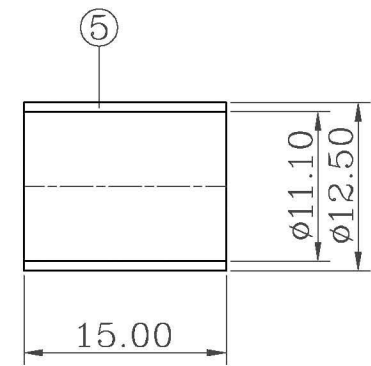
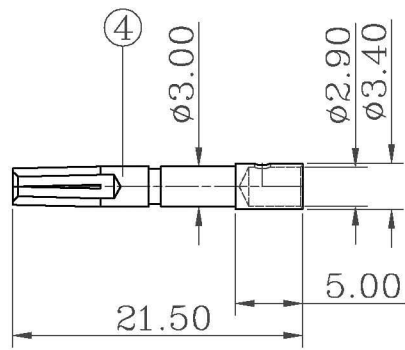
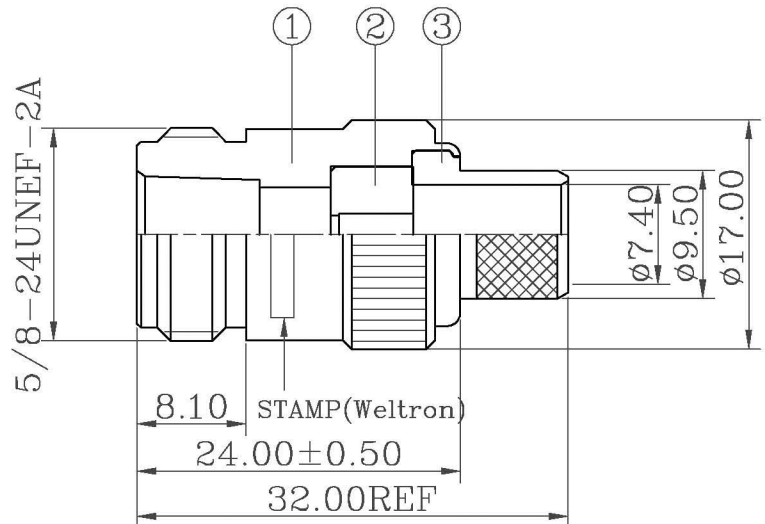

NOTES:FINISH (PLATING THICKNESS IN MICRO-INCHES)

- 1.BRASS PER QQ-B-626
- 2.SILVER PL.100 MIN. THICK OVER COPPER STRIKE
- 3.GOLD PL.3 MIN .THICK OVER NICKEL PL.100 MIN. THICK OVER COPPER STRIKE
- 4.TEFLON MIL-P-19468
- 5.JIS H 3250,C 2700

- 1.CRIMPED FERRULE HEX CRIMP SIZE .429"
- 2. CRIMPED CONTACT PIN HEX CRIMP SIZE .100"

RECOMMENDED  
CABLE STRIPPING DIM'S

5	FERRULE	NOTE 5	1	NOTE 2
4	CONTACT PIN	NOTE 1	1	NOTE 3
3	REAR BODY	NOTE 1	1	NOTE 2
2	INSULATOR	NOTE 4	1	NATURAL
1	BODY	NOTE 1	1	NOTE 2
ITEM	DESCRIPTION	MATERIAL	Q'TY	FINISHED

<b>weltron</b> ®				TITLE		
PART NO.		44-263-LMR400		N CRIMP JACK CRIMP, 50 OHM FOR RG8,BELDEN9913,LMR400 CABLE		
MODEL NO.		UNITS	MM	UNLESS OTHERWISE SPECIFIED TOLERANCES: 0.5-15 = ±0.15    ANGLES ±5° 15-30 = ±0.30 30-120 = ±0.60 >120 = ±1.00	DESIGNED	<i>NQ</i>
		SCALE	FIT		DRAWING	<i>NQ</i>
		EDITION	A1	CHECKED	<i>David</i>	
CAD FILE				PUBLISH DATE	APPROVED	<i>Andy</i>
				2010/01/03	3RD ANGLE	