

ROHS Compliant

REVISIONS

RevNo	Description	Date	Revision	Mender
1	AUGMENT FERRULE	2012/12/14	A2	Bzw
2				

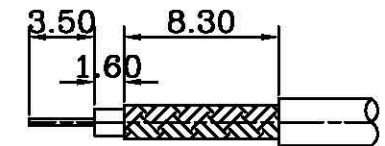
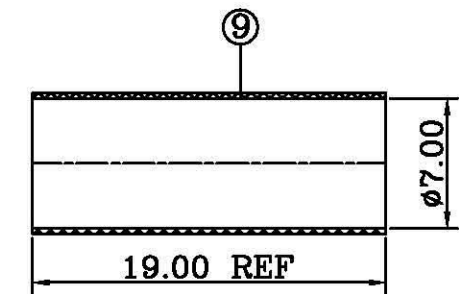
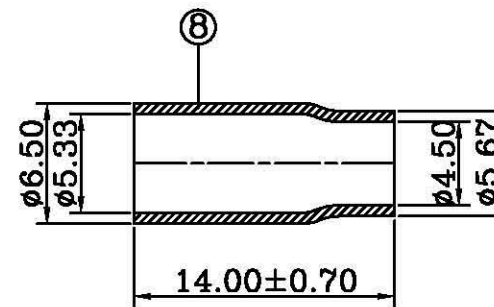
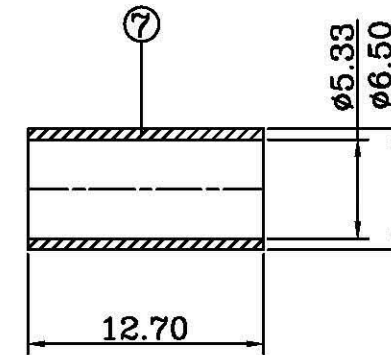
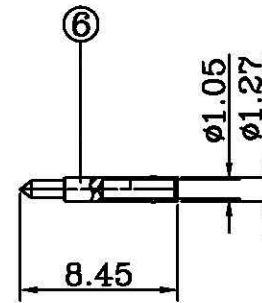
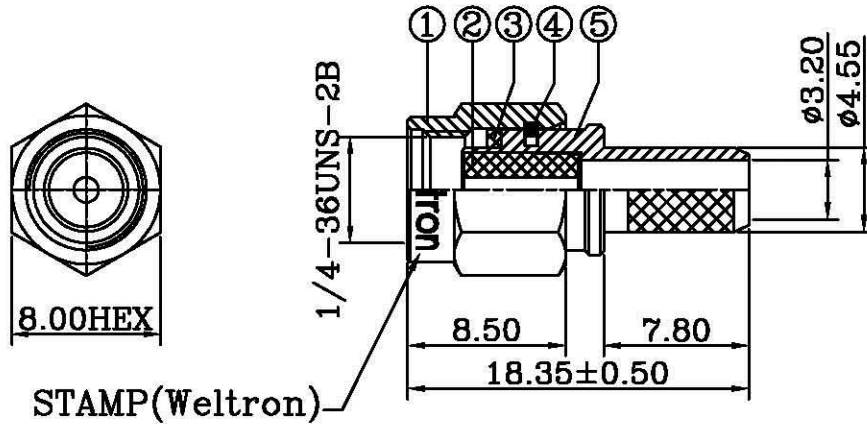

RECOMMENDED
CABLE STRIPPING DIM'S

1. CRIMPED FERRULE HEX CRIMP SIZE .213"
2. CONTACT PIN TO SOLDER

NOTES: FINISH (PLATING THICKNESS IN MICRO-INCHES)

1. BRASS PER QQ-B-626
2. GOLD PL.3 MIN THICK OVER NICKEL PL.100 MIN. THICK OVER COPPER STRIKE
3. JIS H 3250, C 2700

ITEM	DESCRIPTION	MATERIAL	Q'TY	FINISHED
9	HEAT SHRINK TUBE		1	BLACK
8	FERRULE	NOTE 3	1	NOTE 2
7	FERRULE	NOTE 3	1	NOTE 2
6	CONTACT PIN	NOTE 1	1	NOTE 2
5	BODY	NOTE 1	1	NOTE 2
4	RETAINER RING	Be.copper	1	NATURAL
3	GASKET	SILICON	1	RED
2	INSULATOR	TEFLON	1	NATURAL
1	NUT	NOTE 1	1	NOTE 2

<h1>weltron®</h1>				TITLE SMA PLUG CRIMP, 50 OHM (FOR RG58, RG141, LMR195, RG58U-PLENUM CABLE)			
				PART NO. 44-900-58		UNITS MM	
MODEL NO.		SCALE FIT		UNLESS OTHERWISE SPECIFIED TOLERANCES:		DRAWING <i>Ckq</i>	
DRAWING NO.		EDITION A1		PUBLISH DATE		CHECKED <i>David</i>	
CAD FILE Yin sheng/Yifaxing/SMA/SSA1102				2010/01/03		APPROVED <i>Andy</i>	
				3RD ANGLE			