

ROHS Compliant

REVISIONS

RevNo	Description	Date	Revision	Mender
1	AUGMENT FERRULE	2012-12-14	A2	Bzw
2				

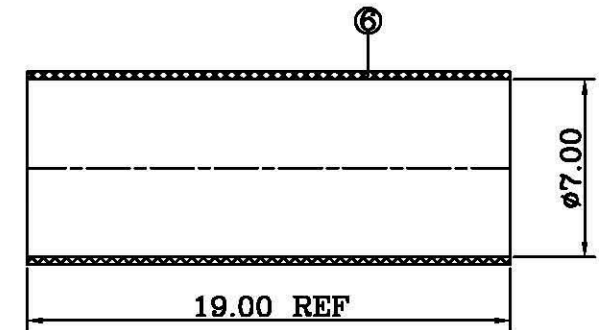
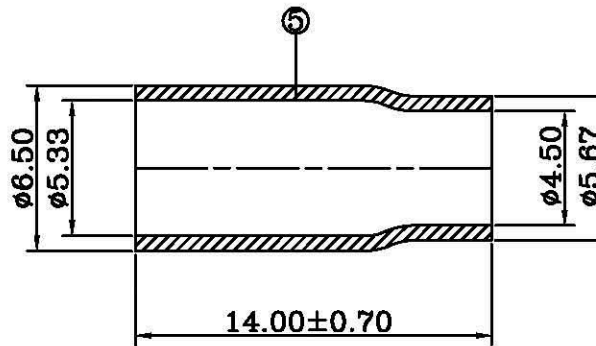
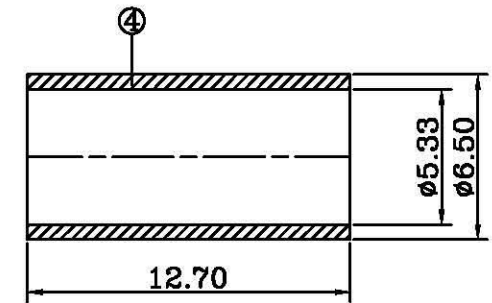
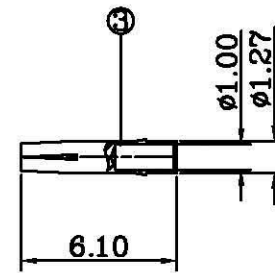
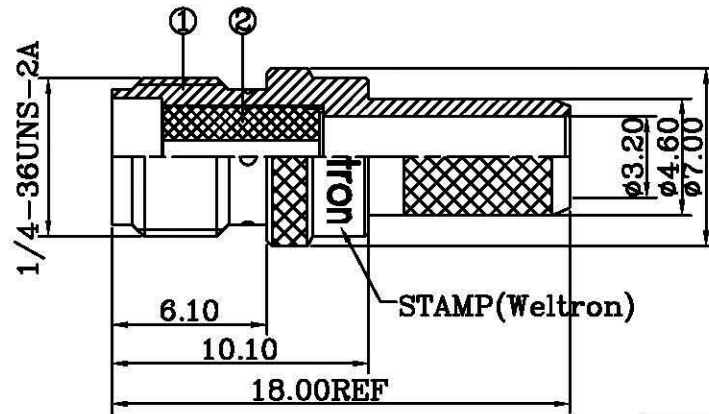

- 1. CRIMPED FERRULE HEX CRIMP SIZE .213"
- 2. CONTACT PIN TO SOLDER

NOTES: FINISH (PLATING THICKNESS IN MICRO-INCHES)

- 1. BRASS PER QQ-B-626
- 2. GOLD PL.3 MIN THICK OVER NICKEL PL.100 MIN. THICK OVER COPPER STRIKE
- 3. TEFLON MIL-P-19468
- 4. BERYLLIUM COPPER PER QQ-C-530
- 5. JIS H 3250, C 2700

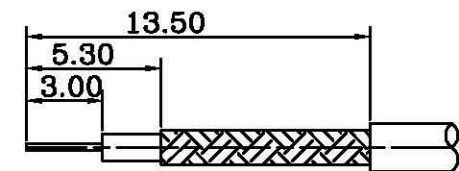

RECOMMENDED CABLE STRIPPING DIM'S

ITEM	DESCRIPTION	MATERIAL	Q'TY	FINISHED
6	HEAT SHRINK TUBE		1	BLACK
5	FERRULE	NOTE 5	1	NOTE 2
4	FERRULE	NOTE 5	1	NOTE 2
3	CONTACT PIN	NOTE 4	1	NOTE 2
2	INSULATOR	NOTE 3	1	NATURAL
1	BODY	NOTE 1	1	NOTE 2

weltron ®				TITLE SMA JACK CRIMP, 50 OHM (FOR RG58, RG141, LMR195, RG58U - PLENUM CABLE)			
PART NO.	44-901-58	UNITS	MM	UNLESS OTHERWISE SPECIFIED TOLERANCES: 0.5-15 = ±0.15 15-30 = ±0.30 30-120 = ±0.60 >120 = ±1.00	DESIGNED	NQ	
MODEL NO.		SCALE	FIT		DRAWING	NQ	
		EDITION	A1	PUBLISH DATE	CHECKED	David	
CAD FILE	Yin sheng/Yifaxing/SSA/SSA1176			2010/01/03	APPROVED	Andy	
					3RD ANGLE		