

ROHS Compliant

REVISIONS

RevNo	Description	Date	Revision	Mender
1				
2				

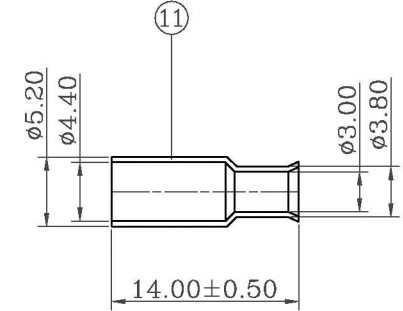
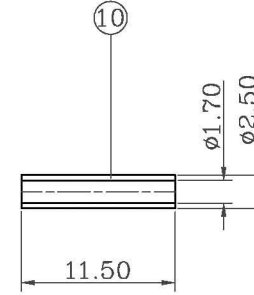
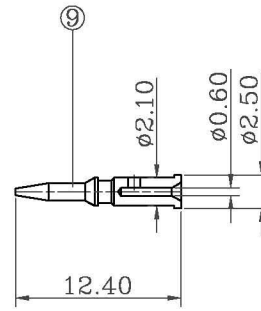
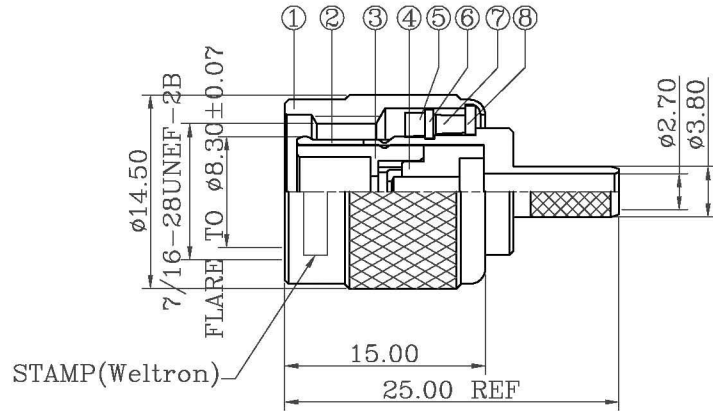

NOTES: FINISH (PLATING THICKNESS IN MICRO-INCHES)

1. BRASS PER QQ-B-626
2. NICKEL PL. 100 MIN. THICK OVER COPPER STRIKE
3. GOLD PL. 3 MIN THICK OVER NICKEL PL. 100 MIN. THICK OVER COPPER STRIKE
4. JIS H 3250, C 2700

1. CRIMPED FERRULE
HEX CRIMP SIZE .178"
2. CRIMPED CONTACT PIN
HEX CRIMP SIZE .068"
OR TO SOLDER

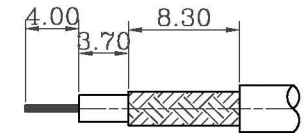

RECOMMENDED
CABLE STRIPPING DIM'S

11	FERRULE	NOTE 4	1	NOTE 2
10	SLEEVE	POM	1	NATURAL
9	CONTACT PIN	NOTE 1	1	NOTE 3
8	WASHER	IRON	1	NOTE 2
7	GASKET	POM	1	NATURAL
6	RETAINER RING	65Mn	1	NOTE 2
5	GASKET	RUBBER	1	RED
4	INSULATOR	POM	1	NATURAL
3	INSULATOR	POM	1	NATURAL
2	BODY	NOTE 1	1	NOTE 2
1	SHELL	NOTE 1	1	NOTE 2
ITEM	DESCRIPTION	MATERIAL	Q'TY	FINISHED

weltron [®]				TITLE TNC CRIMP PLUG 50 OHMS (FOR RG174, 187, 188, 316 CABLE)		
				UNLESS OTHERWISE SPECIFIED TOLERANCES: 0.5-15 = ±0.15 15-30 = ±0.30 30-120 = ±0.60 >120 = ±1.00	ANGLES ±5°	DESIGNED <i>Xwj</i>
PART NO.	44-270-174	UNITS	MM	PUBLISH DATE 2009/12/31		
MODEL NO.		SCALE	FIT			
DRAWING NO.		EDITION	A1	APPROVED <i>Andy</i>	3RD ANGLE	
CAD FILE						