

ROHS Compliant

REVISIONS

RevNo	Description	Date	Revision	Mender
1				
2				

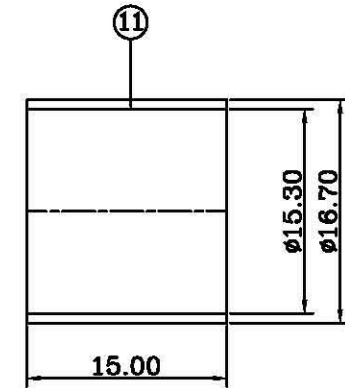
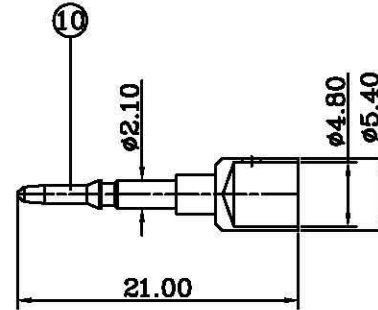
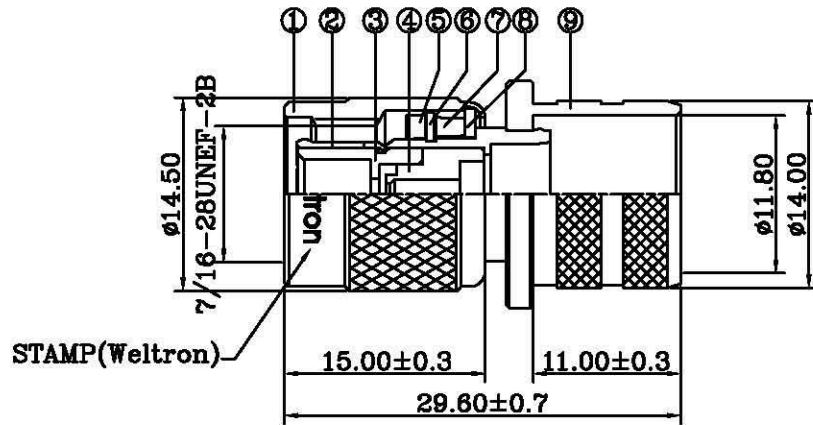

NOTES: FINISH (PLATING THICKNESS IN MICRO-INCHES)

1. BRASS PER QQ-B-626
2. TEFLON MIL-P-19468
3. NICKEL PL.100 MIN. THICK OVER COPPER STRIKE
4. GOLD PL.3 MIN THICK OVER NICKEL PL.100 MIN. THICK OVER COPPER STRIKE
5. JIS H 3250, C 2700

1. CRIMPED FERRULE  
HEX CRIMP SIZE .60"
2. CRIMPED CONTACT PIN  
HEX CRIMP SIZE .187"  
OR TO SOLDER

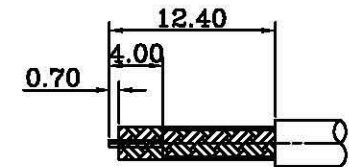

RECOMMENDED  
CABLE STRIPPING DIM'S

ITEM	DESCRIPTION	MATERIAL	Q'TY	FINISHED
11	FERRULE	NOTE 5	1	NOTE 3
10	CONTACT PIN	NOTE 1	1	NOTE 4
9	REAR BODY	NOTE 1	1	NOTE 3
8	WASHER	IRON	1	NOTE 3
7	GASKET	POM	1	NATURAL
6	RETAINER RING	65Mn	1	NOTE 3
5	GASKET	RUBBER	1	RED
4	INSULATOR	NOTE 2	1	NATURAL
3	INSULATOR	NOTE 2	1	NATURAL
2	BODY	NOTE 1	1	NOTE 3
1	SHELL	NOTE 1	1	NOTE 3

<b>weltron</b> <sup>®</sup>				TITLE TNC CRIMP PLUG 50 OHMS FOR LMR600 CABLE			
				PART NO. 44-270-LMR600		UNITS	MM
MODEL NO.		SCALE	FIT	TOLERANCES:		DESIGNED	<i>Ckq</i>
DRAWING NO.		EDITION	A1	0.5-15 = ±0.15		DRAWING	<i>Ckq</i>
CAD FILE		Yin sheng/Yifaxing/ST/ST208		15-30 = ±0.30		CHECKED	<i>David</i>
				30-120 = ±0.60		APPROVED	<i>Andy</i>
				>120 = ±1.00		PUBLISH DATE	
				ANGLES ±5°		2012/12/10	
				3RD ANGLE			