

ROHS Compliant

REVISIONS

RevNo	Description	Date	Revision	Mender
1				
2				

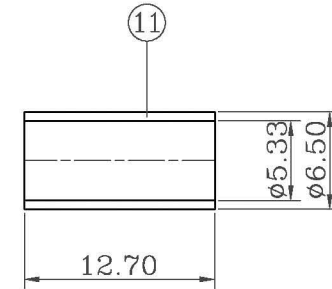
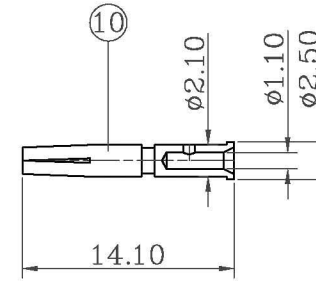
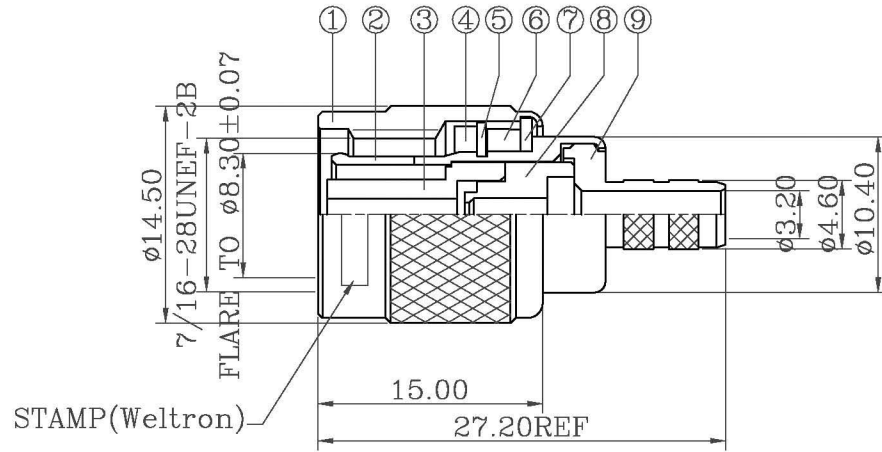

NOTES:FINISH (PLATING THICKNESS IN MICRO-INCHES)

- 1.BRASS PER QQ-B-626
- 2.NICKEL PL.100 MIN. THICK OVER COPPER STRIKE
- 3.GOLD PL.3 MIN THICK OVER NICKEL PL.100 MIN. THICK OVER COPPER STRIKE
- 4.JIS H 3250,C 2700

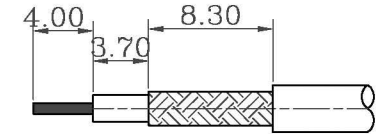

RECOMMENDED CABLE STRIPPING DIM'S

- 1.CRIMPED FERRULE
HEX CRIMP SIZE .213"
- 2.CRIMPED CONTACT PIN
HEX CRIMP SIZE .068"
OR TO SOLDER

11	FERRULE	NOTE 4	1	NOTE 2
10	CONTACT PIN	NOTE 1	1	NOTE 3
9	REAR BODY	NOTE 1	1	NOTE 2
8	INSULATOR	TEFLON	1	NATURAL
7	WASHER	IRON	1	NOTE 2
6	GASKET	POM	1	NATURAL
5	RETAINER RING	65Mn	1	NOTE 2
4	GASKET	RUBBER	1	RED
3	INSULATOR	TEFLON	1	NATURAL
2	BODY	NOTE 1	1	NOTE 2
1	SHELL	NOTE 1	1	NOTE 2
ITEM	DESCRIPTION	MATERIAL	Q'TY	FINISHED

weltron [®]				TITLE TNC REVERSE POLARITY CRIMP PLUG 50 OHMS FOR RG58, 141, LMR195 CABLE				
				UNLESS OTHERWISE SPECIFIED TOLERANCES: 0.5-15 = ±0.15 15-30 = ±0.30 30-120 = ±0.60 >120 = ±1.00	ANGLES ±5°	DESIGNED <i>Xwj</i>	DRAWING <i>Ckq</i>	CHECKED <i>David</i>
PART NO.	44-270RP-58	UNITS SCALE	MM FIT	EDITION	A1	PUBLISH DATE	2009/12/31	APPROVED <i>Andy</i>
MODEL NO.								3RD ANGLE
CAD FILE								