

ROHS Compliant

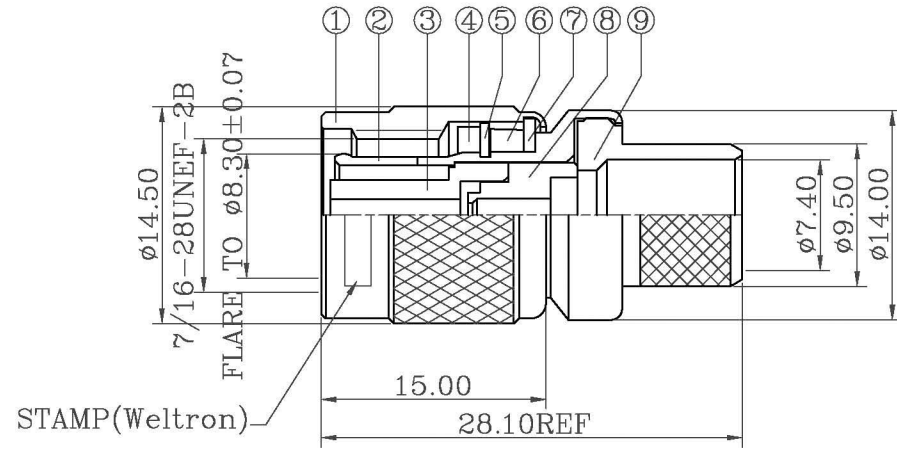

REVISIONS				
RevNo	Description	Date	Revision	Mender
1				
2				

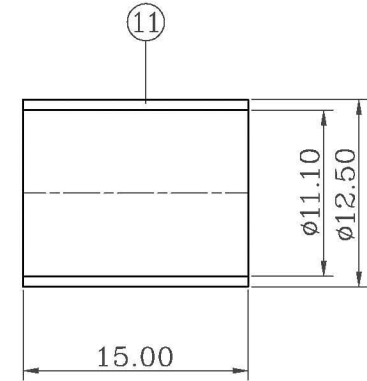
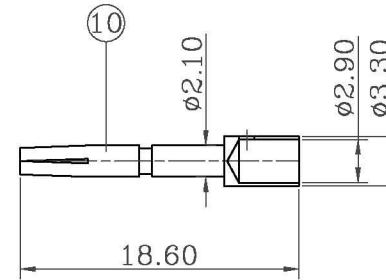

NOTES:FINISH (PLATING THICKNESS IN MICRO-INCHES)

- 1.BRASS PER QQ-B-626
- 2.NICKEL PL.100 MIN. THICK OVER COPPER STRIKE
- 3.GOLD PL.3 MIN THICK OVER NICKEL PL.100 MIN. THICK OVER COPPER STRIKE
- 4.JIS H 3250,C 2700

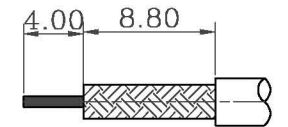

RECOMMENDED  
CABLE STRIPPING DIM'S

- 1.CRIMPED FERRULE  
HEX CRIMP SIZE .429"
- 2.CRIMPED CONTACT PIN  
HEX CRIMP SIZE .100"  
OR TO SOLDER

11	FERRULE	NOTE 4	1	NOTE 2
10	CONTACT PIN	NOTE 1	1	NOTE 3
9	REAR BODY	NOTE 1	1	NOTE 2
8	INSULATOR	TEFLON	1	NATURAL
7	WASHER	IRON	1	NOTE 2
6	GASKET	POM	1	NATURAL
5	RETAINER RING	65Mn	1	NOTE 2
4	GASKET	RUBBER	1	RED
3	INSULATOR	TEFLON	1	NATURAL
2	BODY	NOTE 1	1	NOTE 2
1	SHELL	NOTE 1	1	NOTE 2
ITEM	DESCRIPTION	MATERIAL	Q'TY	FINISHED

<b>weltron</b> <sup>®</sup>				TITLE TNC REVERSE POLARITY CRIMP PLUG 50 OHMS FOR RG8U, BELDEN9913, LMR400 CABLE		
				UNLESS OTHERWISE SPECIFIED TOLERANCES: 0.5-15 = ±0.15    ANGLES ±5° 15-30 = ±0.30 30-120 = ±0.80 >120 = ±1.00		DESIGNED
PART NO.	44-270RP-LMR400	UNITS	MM	DRAWING	<i>Ckq</i>	
		SCALE	FIT	CHECKED	<i>David</i>	
MODEL NO.		EDITION	A1	APPROVED	<i>Andy</i>	
CAD FILE		PUBLISH DATE		2009/12/31		
				3RD ANGLE		