

ROHS Compliant

REVISIONS

RevNo	Description	Date	Revision	Mender
1				
2				

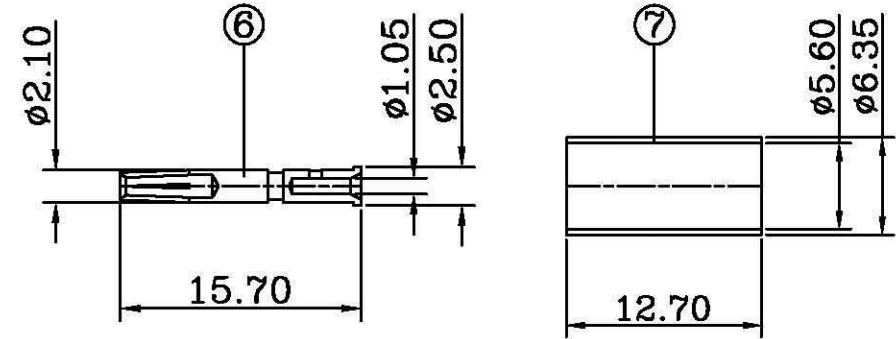
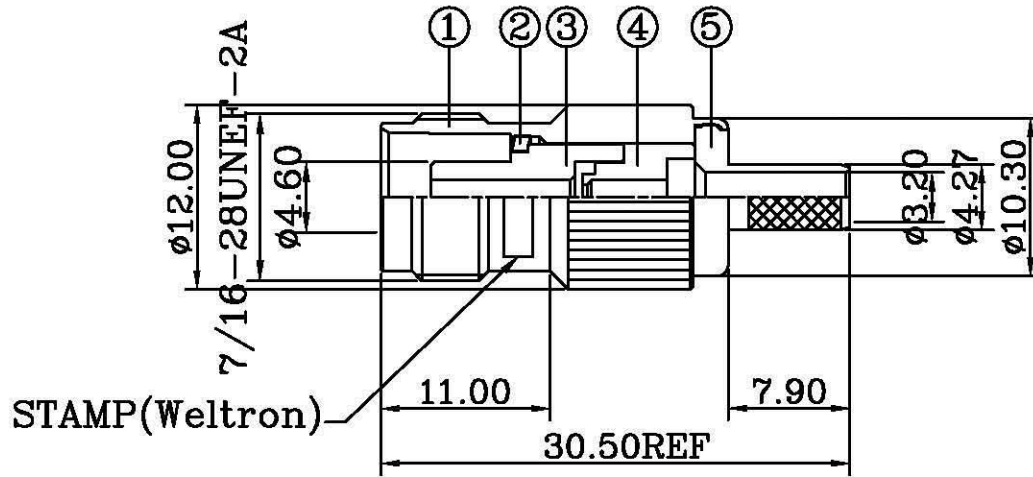

NOTES: FINISH (PLATING THICKNESS IN MICRO-INCHES)

1. BRASS PER QQ-B-626
2. NICKEL PL. 100 MIN. THICK OVER COPPER STRIKE
3. GOLD PL. 3 MIN THICK OVER NICKEL PL. 100 MIN. THICK OVER COPPER STRIKE
4. JIS H 3250, C 2700

1. CRIMPED FERRULE
HEX CRIMP SIZE .213"
2. CRIMPED CONTACT PIN
HEX CRIMP SIZE .068"
OR TO SOLDER

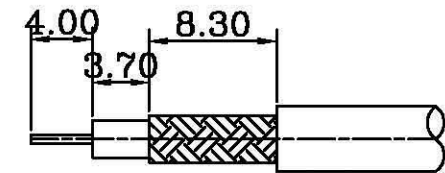

RECOMMENDED
CABLE STRIPPING DIM'S

7	FERRULE	NOTE 4	1	NOTE 2
6	CONTACT PIN	NOTE 1	1	NOTE 3
5	REAR BODY	NOTE 1	1	NOTE 2
4	INSULATOR	TEFLON	1	WHITE
3	INSULATOR	TEFLON	1	WHITE
2	WASHER	IRON	1	NOTE 2
1	BODY	NOTE 1	1	NOTE 2
ITEM	DESCRIPTION	MATERIAL	Q'TY	FINISHED

<h1>Weltron®</h1>				TITLE		
				TNC CRIMP JACK 50 OHMS (FOR RG55, 142, 223 CABLE)		
PART NO.	44-273-223	UNITS	MM	UNLESS OTHERWISE SPECIFIED TOLERANCES: 0.5-15 = ±0.15 ANGLES 15-30 = ±0.30 ±5° 30-120 = ±0.60 >120 = ±1.00	DESIGNED	NQ
MODEL NO.		SCALE	FIT		DRAWING	NQ
DRAWING NO.		EDITION	A1	PUBLISH DATE	CHECKED	David
				2012/12/15	APPROVED	Andy
					☐ ⊕ 3RD ANGLE	