

ROHS Compliant

REVISIONS

RevNo	Description	Date	Revision	Mender
1				
2				

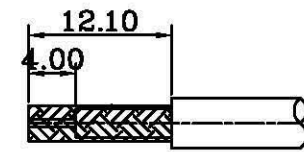
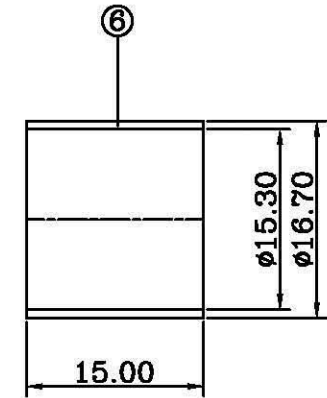
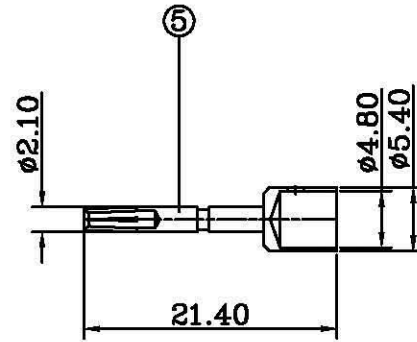
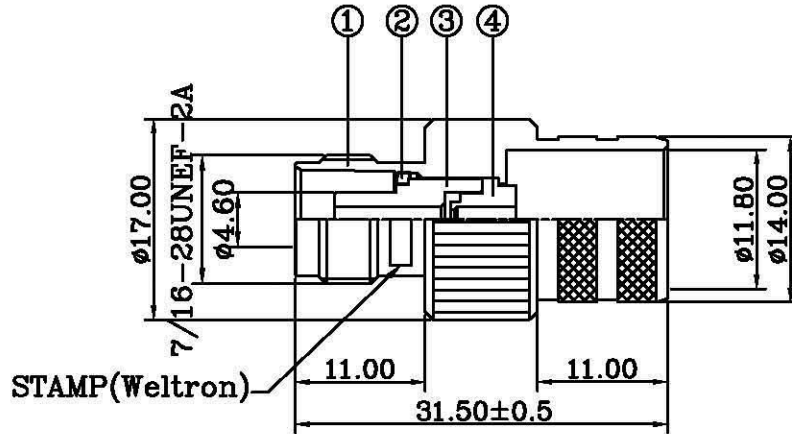

NOTES:FINISH (PLATING THICKNESS IN MICRO-INCHES)

- 1.BRASS PER QQ-B-626
- 2.NICKEL PL.100 MIN. THICK OVER COPPER STRIKE
- 3.GOLD PL.3 MIN THICK OVER NICKEL PL.100 MIN. THICK OVER COPPER STRIKE
- 4.JIS H 3250,C 2700

- 1.CRIMPED FERRULE
HEX CRIMP SIZE .60"
- 2.CRIMPED CONTACT PIN
HEX CRIMP SIZE .187"
OR TO SOLDER

RECOMMENDED
CABLE STRIPPING DIM'S

ITEM	DESCRIPTION	MATERIAL	Q'TY	FINISHED
6	FERRULE	NOTE 4	1	NOTE 2
5	CONTACT PIN	NOTE 1	1	NOTE 3
4	INSULATOR	TEFLON	1	WHITE
3	INSULATOR	TEFLON	1	WHITE
2	WASHER	IRON	1	NOTE 2
1	BODY	NOTE 1	1	NOTE 2

<h1>weltron®</h1>				TITLE TNC CRIMP JACK 50 OHMS FOR LMR600 CABLE			
PART NO.	44-273-LMR600	UNITS	MM	UNLESS OTHERWISE SPECIFIED TOLERANCES: 0.5-15 = ±0.15 ANGLES 15-30 = ±0.30 ±5° 30-120 = ±0.60 >120 = ±1.00		DESIGNED	<i>Ckq</i>
MODEL NO.		SCALE	FIT			DRAWING	<i>Ckq</i>
DRAWING NO.		EDITION	A1	PUBLISH DATE	2012/12/17	CHECKED	<i>David</i>
						APPROVED	<i>Andy</i>
						☐ ⊕ 3RD ANGLE	